

PKS-PRO-E-08 - Servo System

FEATURES

- **Input Voltage Range of 85-253 VAC**
- **Rated Torque of 338 oz-in**
- **750 Watt Power Rating**
- **No Load Speed of up to 4,500 RPM**
- **2,500 PPR Incremental Encoder**
- **Enclosed and Self-Cooled**
- **Oil Seal and Optional Brake**
- **MODBUS and CANopen Standard**
- **RS485 Interface**
- **Real Time Monitoring and Management**
- **Position, Speed, and Torque Control**
- **CE Certified**



DESCRIPTION

The PKS-PRO-E-08 servo system includes a 750 Watt EMJ motor operated by the PRONET-E drive. These packages are ideal for quick and easy start-ups, convenience and performance! The servo motors included in these packages provide torque up to 338 oz-in. The PRONET-E drives offer current forward-feedback control, acceleration forward-feedback control, speed viewer, and inertia viewer; providing for improved response performance. These drives operate standard with MODBUS and CANopen protocol. Each system includes a 5m power cable, 5m encoder cable, and a 3m communication cable.

System Specs	Rated Voltage (VAC)	Rated Speed (RPM)	Rated Torque (oz-in)	Rated Current (A rms)	Inertia (oz-in-sec ²)	Torque Constant KT (oz-in/A)	Resistance (ohms)	Inductance (mH)	Driver Digital Display	Brake (24VDC)	Motor Length (mm)	Shaft Diameter (mm)
PKS-PRO-E-08-A-JP22	170-253	3000	338	4.0	0.0191	86.8	2.0	16.5	Yes	No	138	19.0
PKS-PRO-E-08-A-JP24	170-253	3000	338	4.0	0.0208	86.8	2.0	16.5	Yes	Yes	181	19.0
PKS-PRO-E-08-B-JP22	85-132	3000	338	8.2	0.0191	48.3	0.713	2.55	Yes	No	138	19.0

ORDERING INFORMATION

PKS - PRO - E - 08 - A - J P 2 2

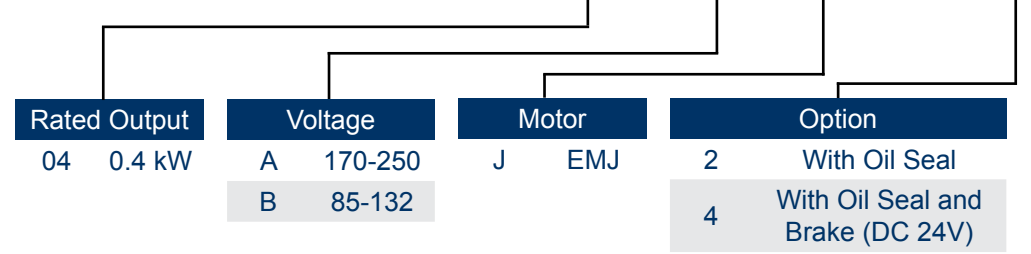

L010955

EMJ-08 Motor Specifications



FEATURES

- Rated Torque of 338 oz-in
- 3-Phase, 200VAC
- Rated Power up to 750 Watts
- Peak Torque up to 300% of Rated Torque
- Peak Current up to 300% of Rated Current
- No Load Speed of up to 4,500 RPM
- 2,500 PPR Incremental Encoder Attached
- Fully Enclosed and Self-Cooled
- Neodymium-Iron-Boron Magnets (NdFeB)
- Optional Brake Available
- CE Certified



SPECIFICATIONS

Motor Specifications	Rated Voltage (VAC)	Rated Power (Watts)	Rated Speed (RPM)	Rated Torque (oz-in)	Rated Current (A rms)	Max Current (A rms)	Brake (24VDC)	Resistance (ohms)	Inertia (oz-in-sec ²)	Electric Time Constant T _E (ms)	Back EMF Voltage K _E (V/kRPM)	Torque Constant K _T (oz-in/A)	Max Length L (mm)	Weight (lbs)
EMJ-08APB22	170-253	450	3000	338	4.0	12	No	2.0	0.0191	11.0	39	86.8	138	7.72
EMJ-08APB24	170-253	450	3000	338	4.0	12	Yes	2.0	0.0208	11.0	39	86.8	181	7.72
EMJ-08BPB22	85-132	450	3000	338	8.2	24.6	No	0.713	1.35	3.58	20.5	0.341	138	7.72

DIMENSIONS

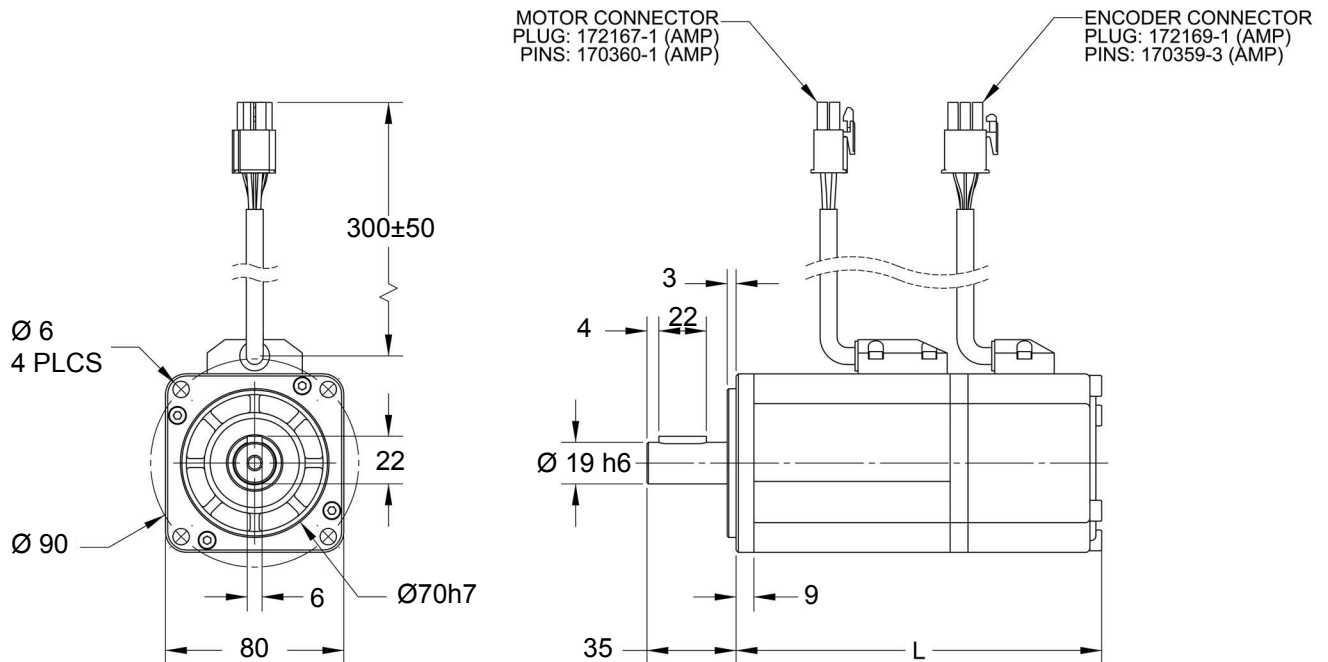

Note: Part Number EMJ-08APB24 is with the brake option. Brake option not shown in above dimensions.

Dimensions are in mm

PRO-E-08A Driver Specifications

FEATURES

- Input Voltage Range of 170-253 VAC
- Rated Power up to 750 Watts
- Improved Responsiveness Performance
- Enhanced Position Precision
- Low Speed Stability
- Enables Less Debugging
- MODBUS and CANopen Standard
- RS485 Communication Interface
- Position, Speed, and Torque Control
- Homing Function



ProNet DIMENSIONS

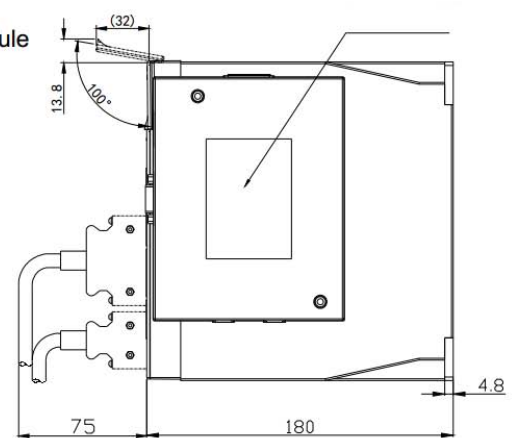
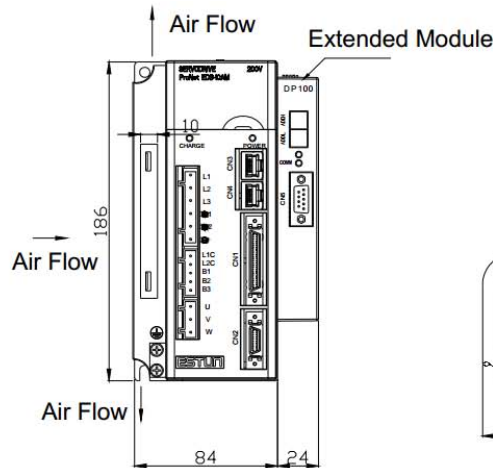
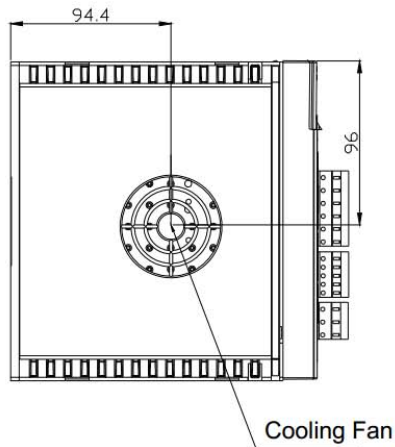

Dimensions are in mm

TORQUE CURVE

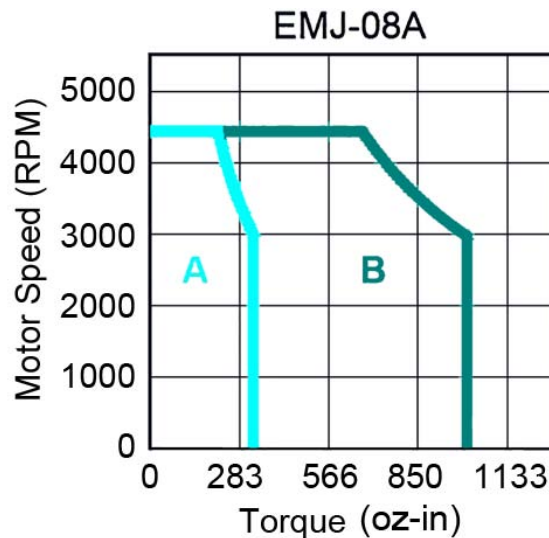

A - Continuous Working Area

B - Repeatedly Working Area

PRO-E-08B Driver Specifications

FEATURES

- Input Voltage Range of 85-132 VAC
- Rated Power up to 750 Watts
- Improved Responsiveness Performance
- Enhanced Position Precision
- Low Speed Stability
- Enables Less Debugging
- MODBUS and CANopen Standard
- RS485 Communication Interface
- Position, Speed, and Torque Control
- Homing Function



ProNet DIMENSIONS

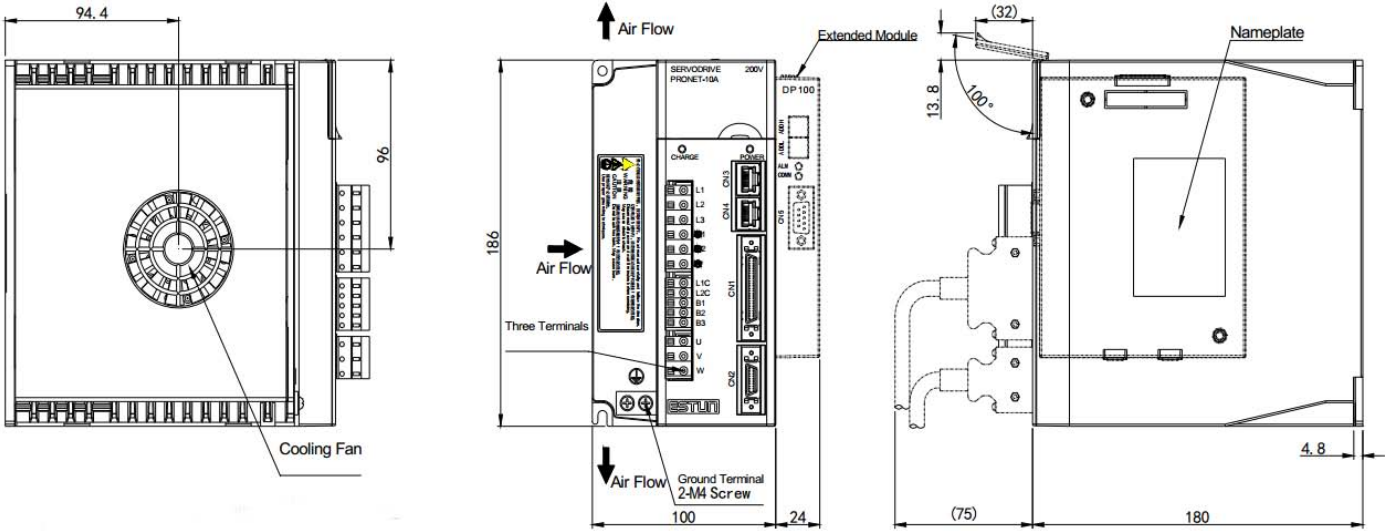

Dimensions are in mm

TORQUE CURVE

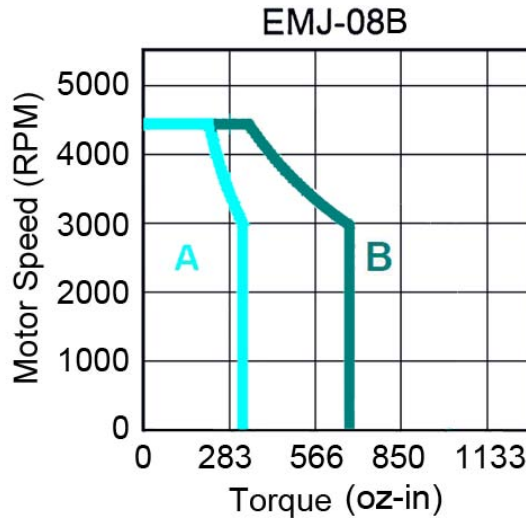

A - Continuous Working Area

B - Repeatedly Working Area

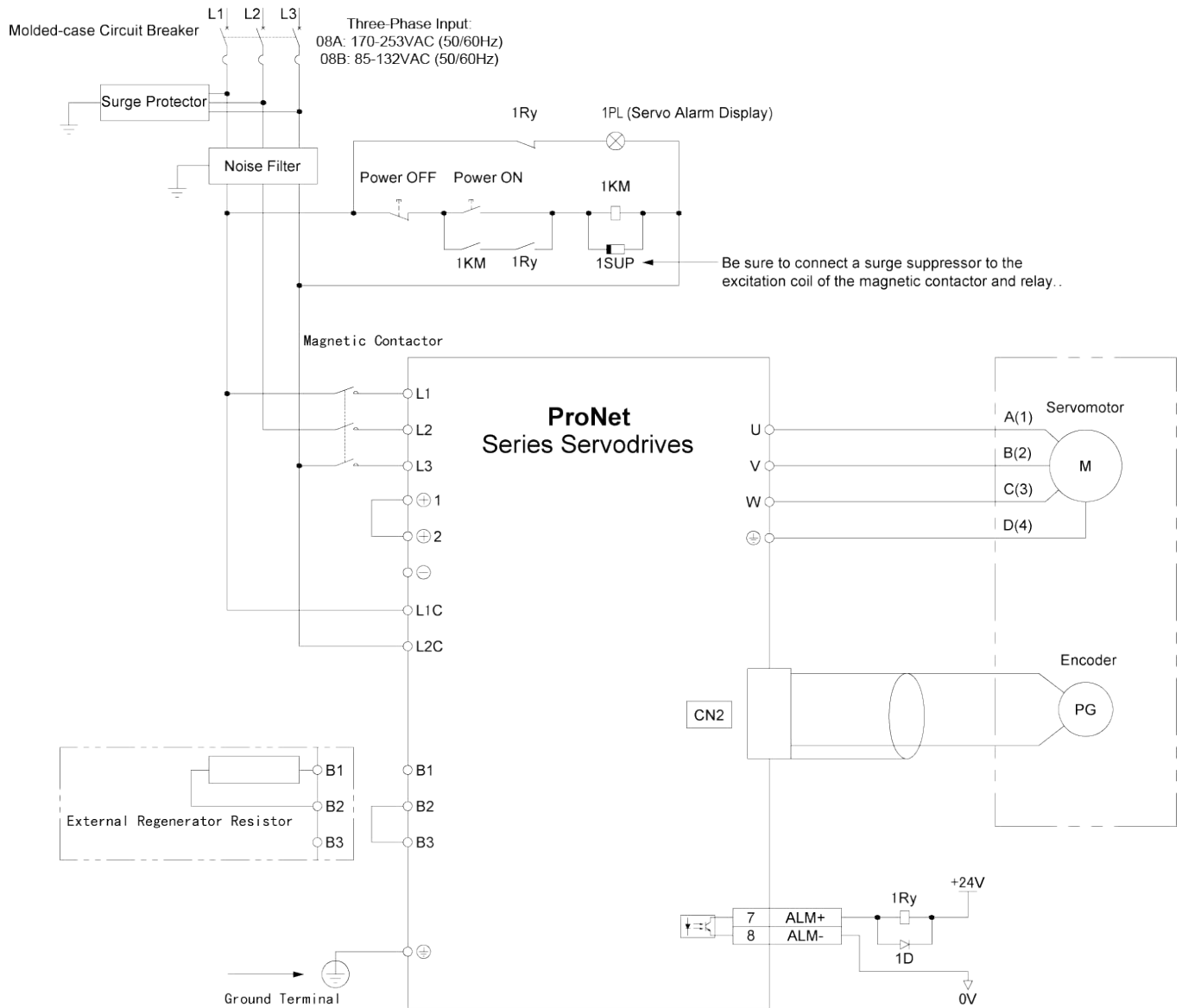

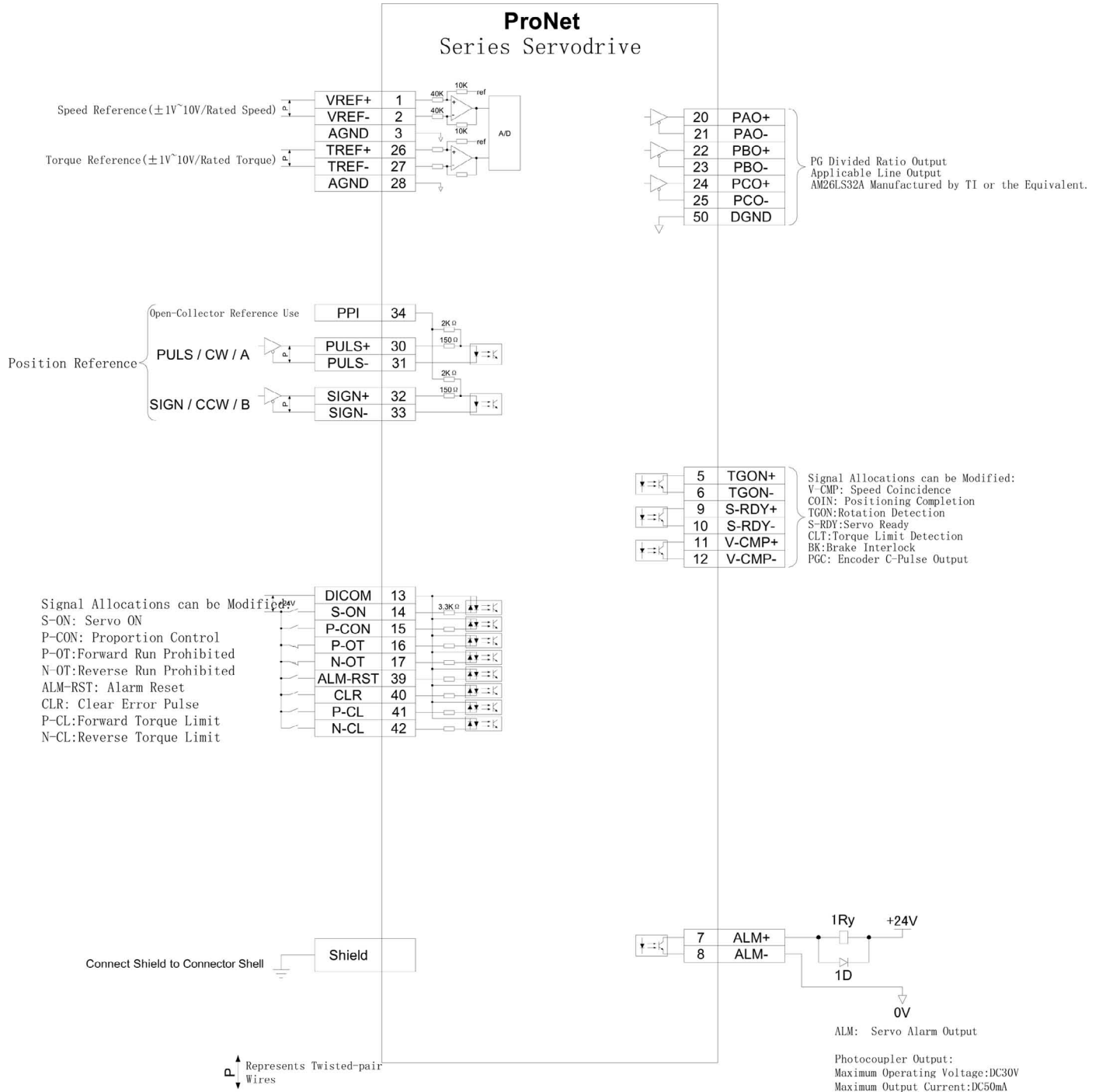

Compatible Drivers

Part Number	Description
PRONET-E-08A	Servo Driver



Compatible Motors

Part Number	Description
EMJ-08APB22	Servo Motor
EMJ-08APB24	Servo Motor



Compatible Cables

Part Number	Description
PDM-JB18-05	Power Cable
BMP-JB24-05	Encoder Cable
PRONET-PSC-CC24-02	Comm. Cable
PRONET-USB-RS485	Comm. Cable

